

VICTORIAN RAILWAYS.

DRAWING N^o 5.
CONTRACT N^o 532

BRICK CULVERTS

Scale, 4 feet to 1 in^h

The figures at the back of curved wings on plan represent the heights of those points above top of footings; the arc being divided into four equal parts.

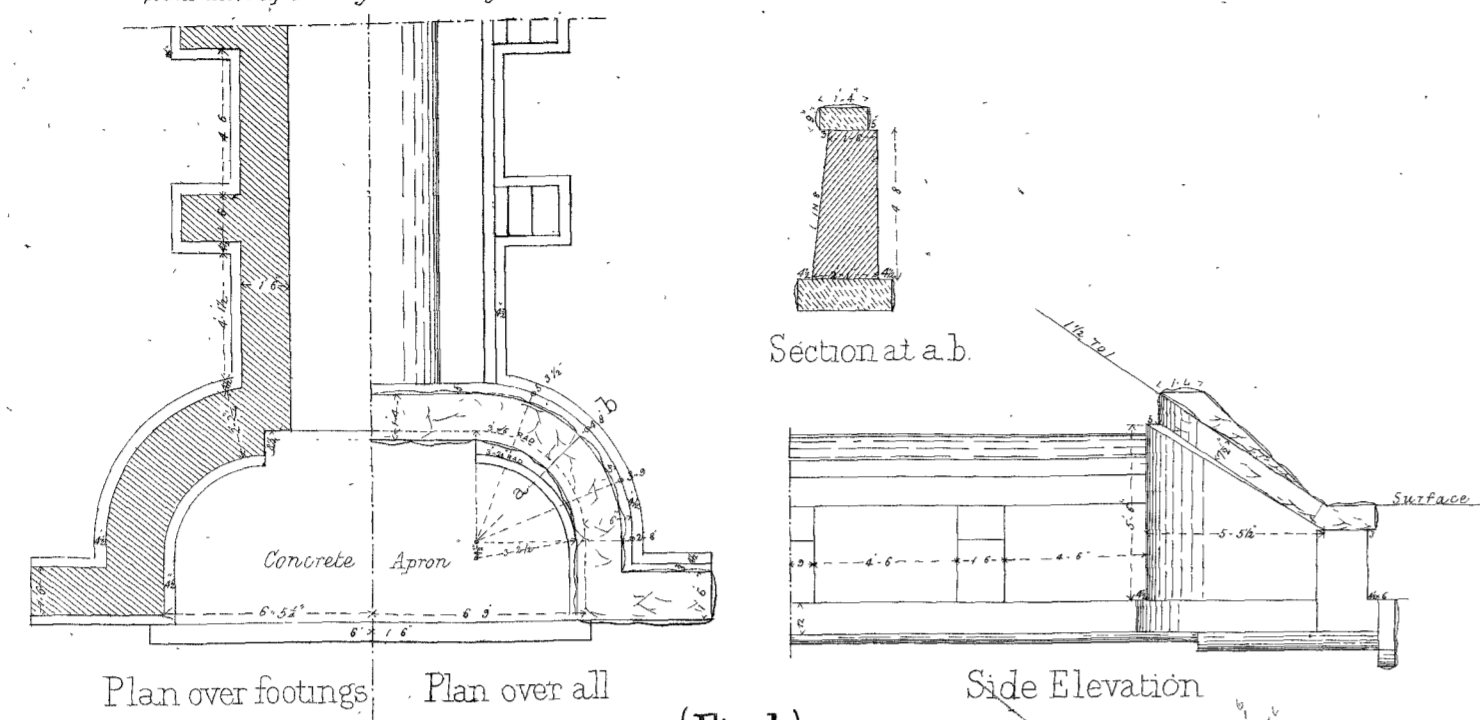

(Fig 1)
5' x 5' WITH CURVED WINGS

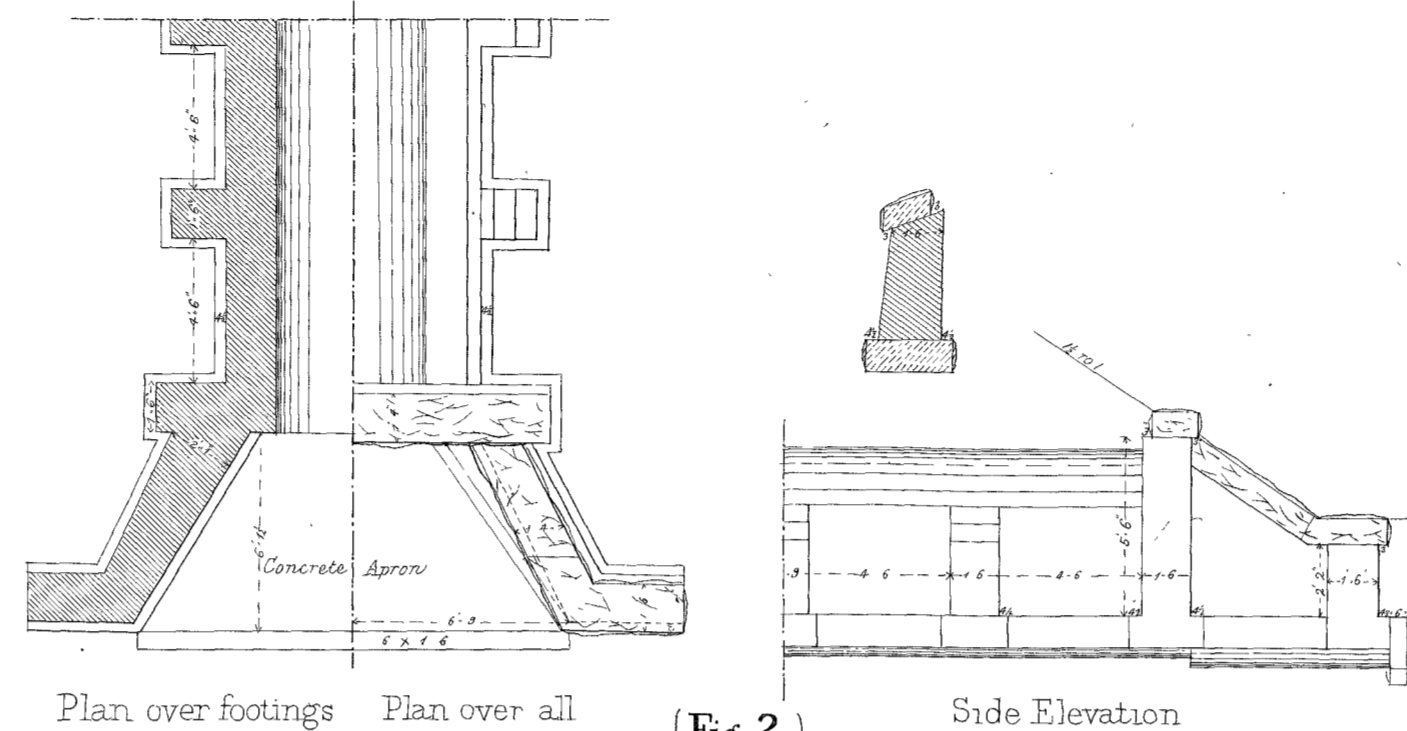
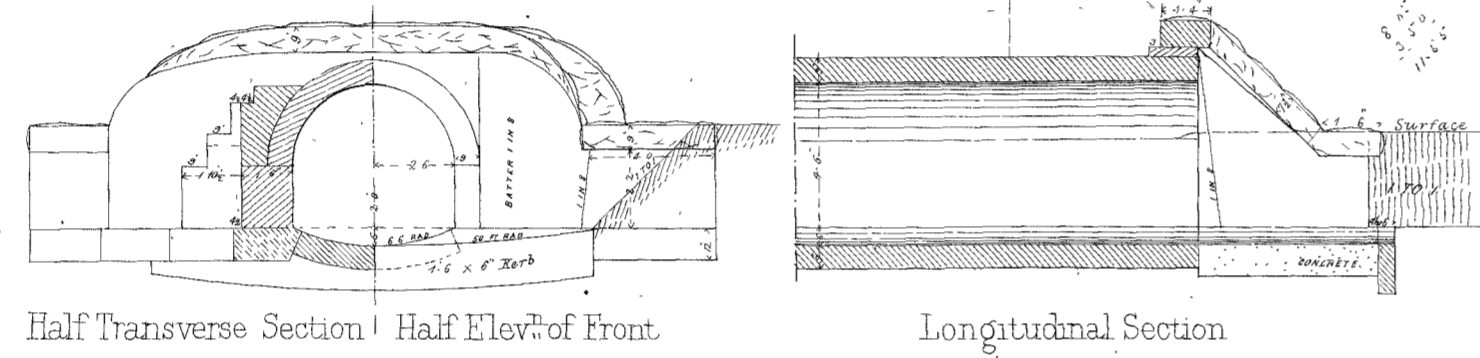

(Fig 2)
5' x 5' WITH STRAIGHT WINGS

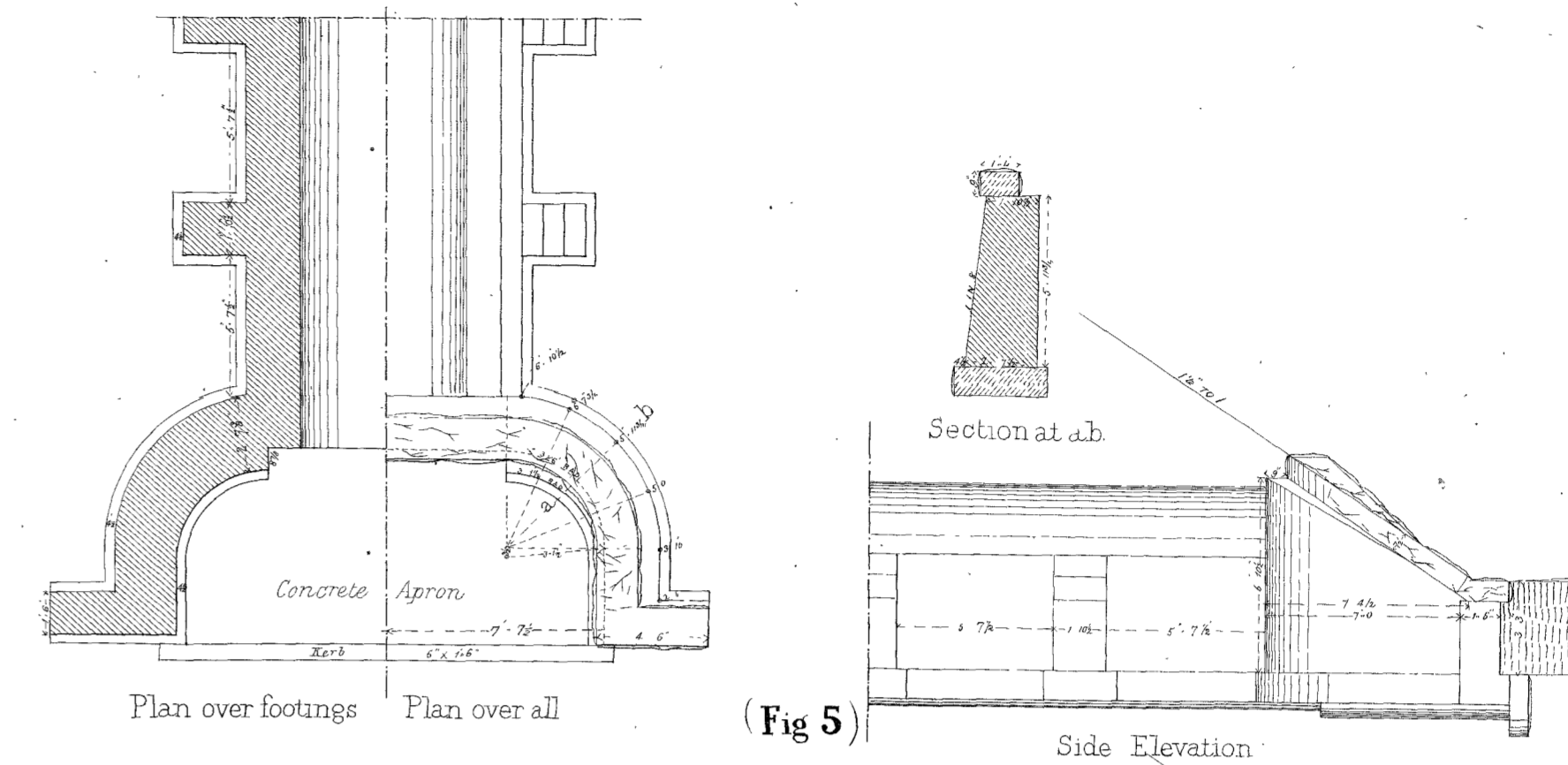
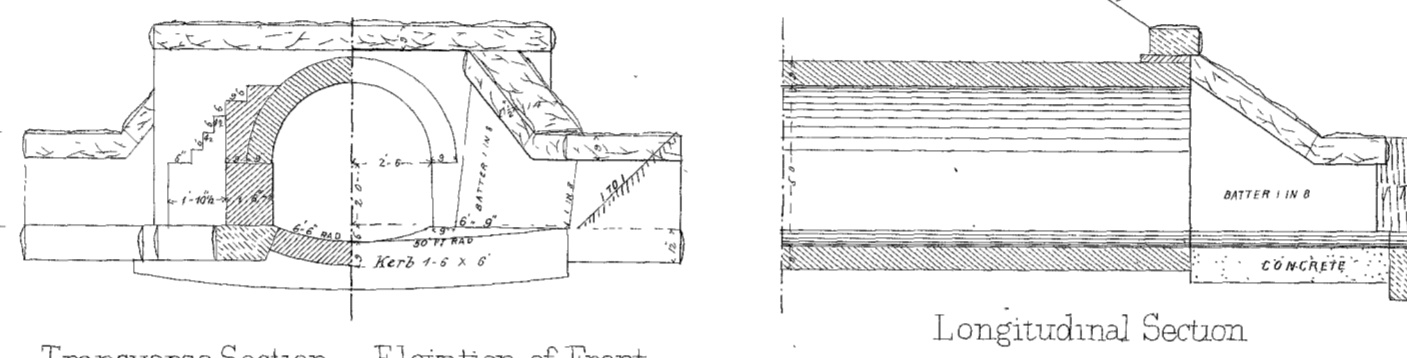

(Fig 5)
6' x 6' WITH CURVED WINGS

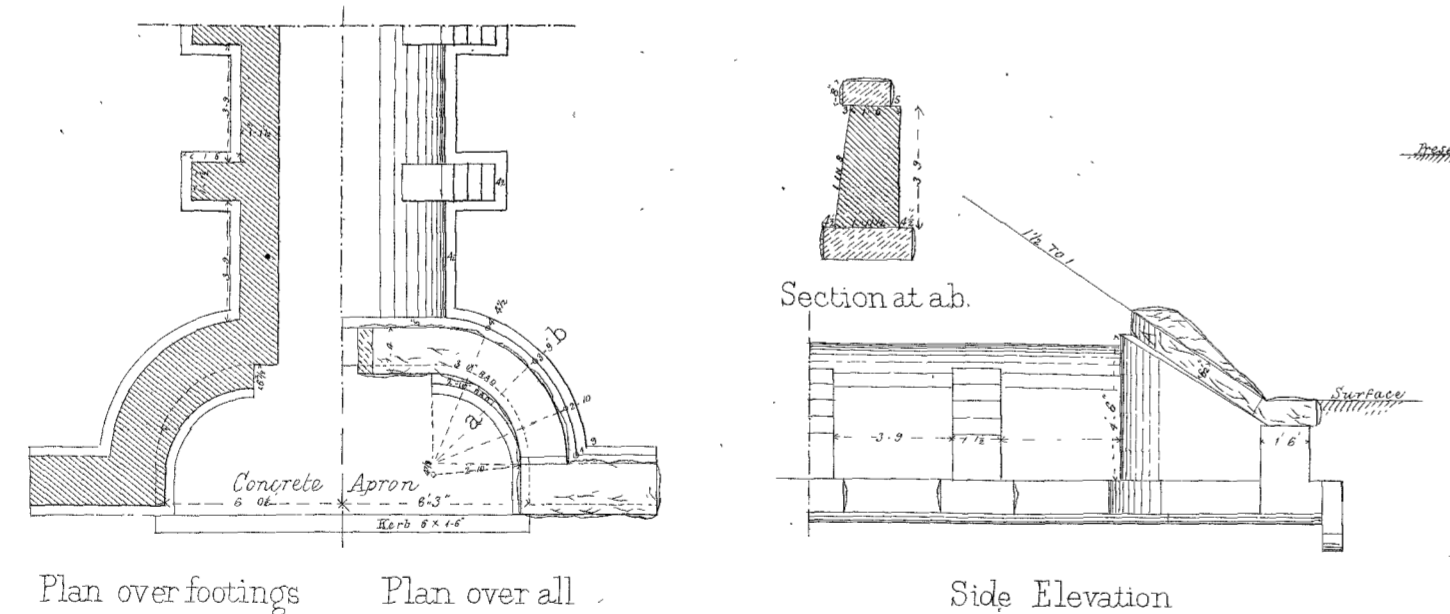
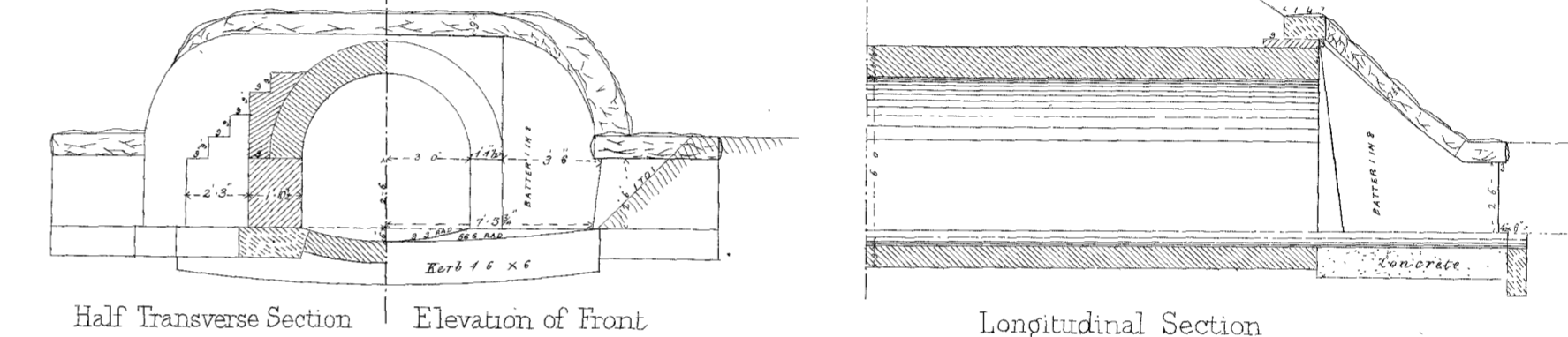

(Fig 3)
4' x 4' WITH CURVED WINGS

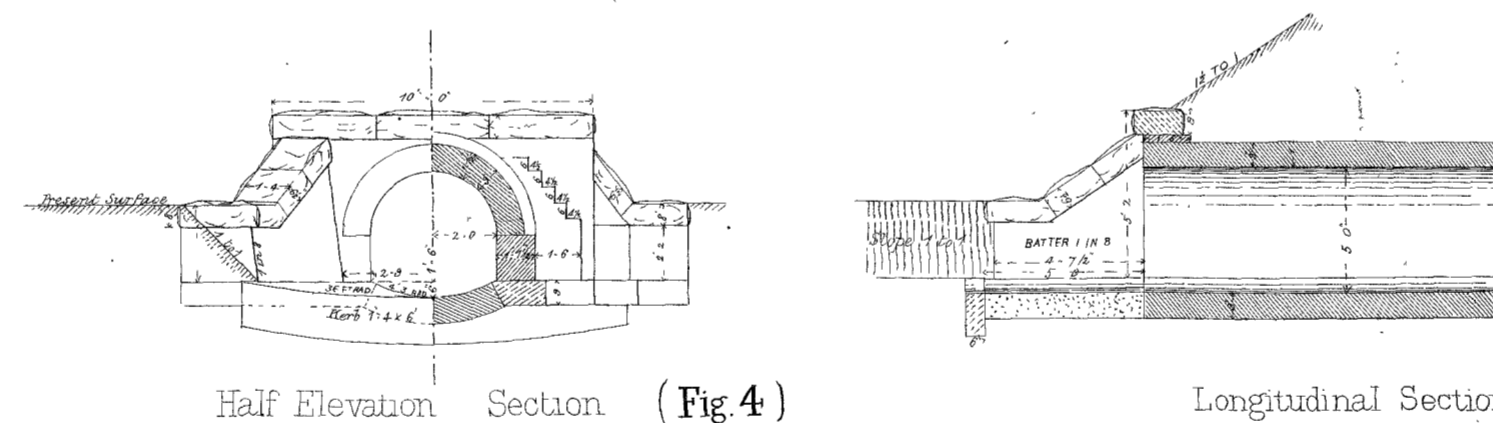
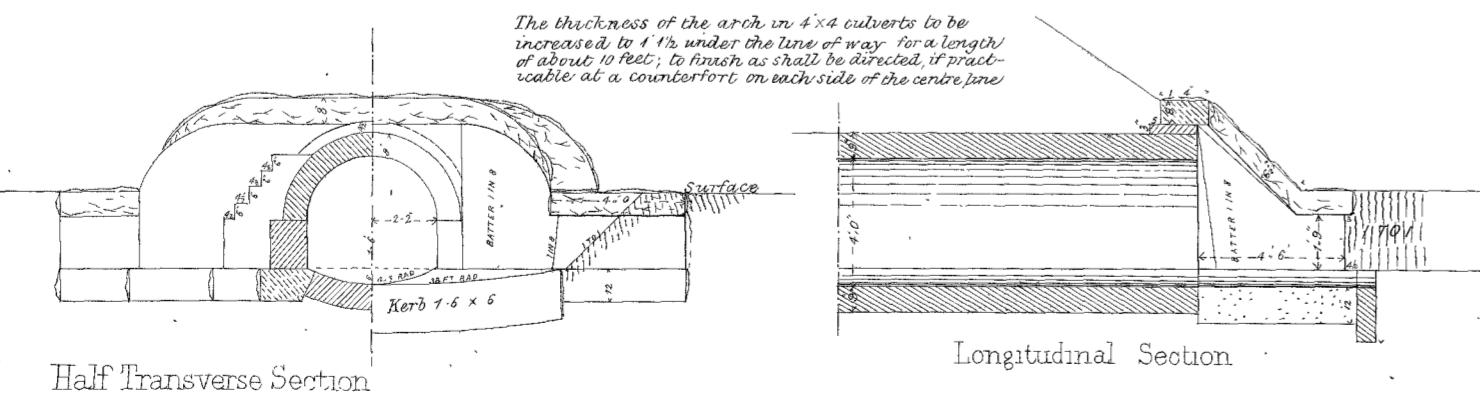

(Fig 4)
4' x 4' WITH STRAIGHT WINGS

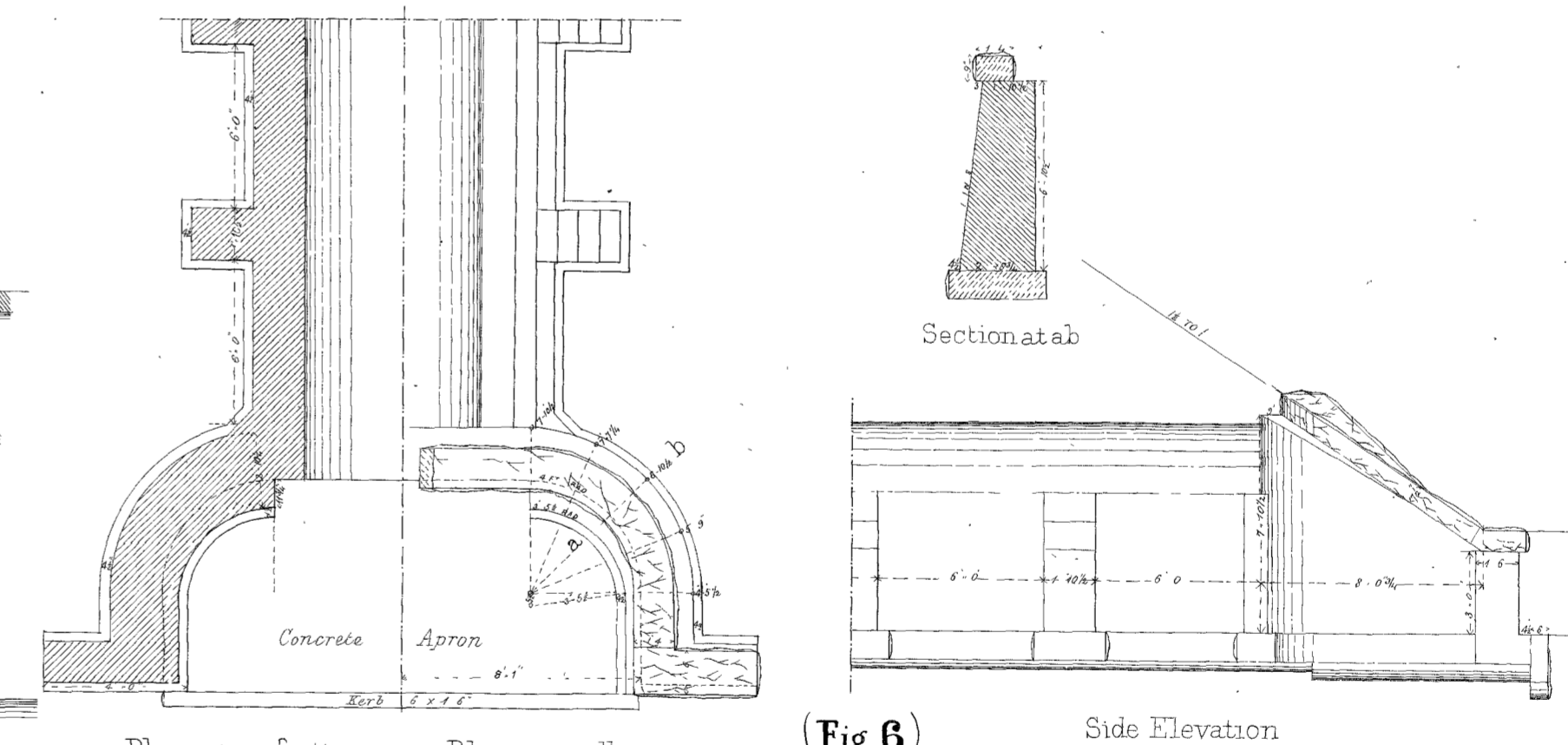
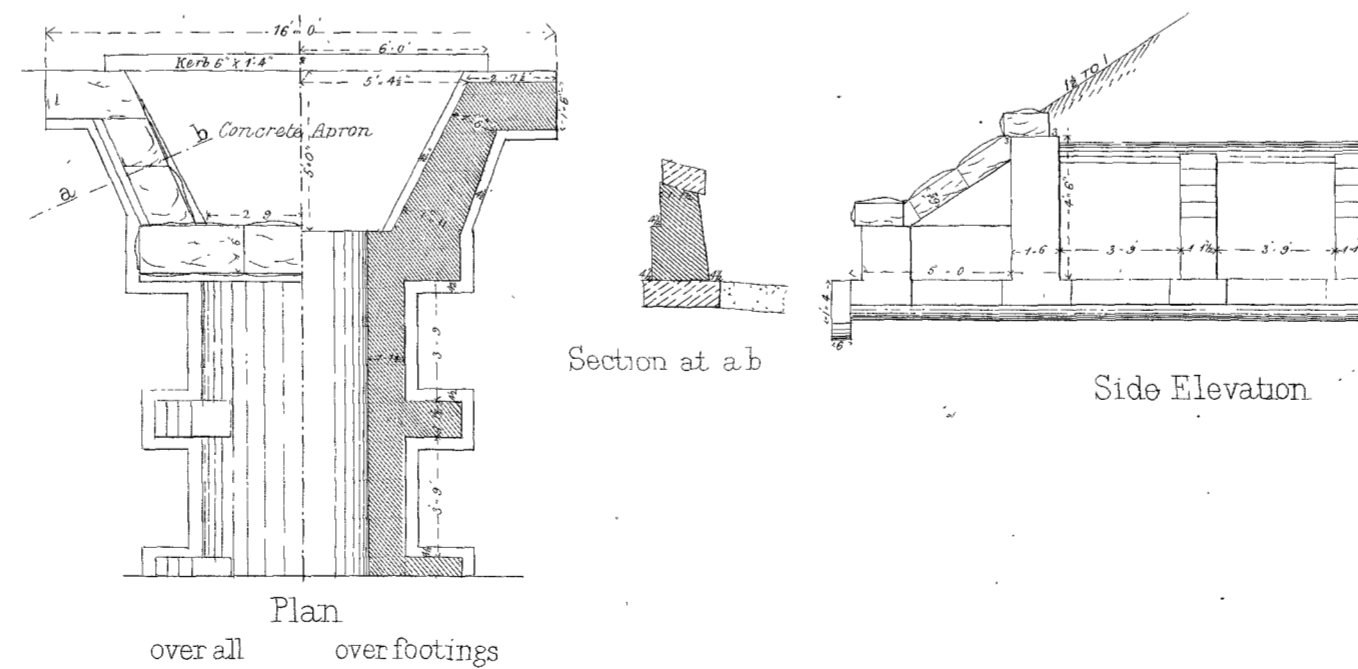

(Fig 6)
7' x 7' WITH CURVED WINGS

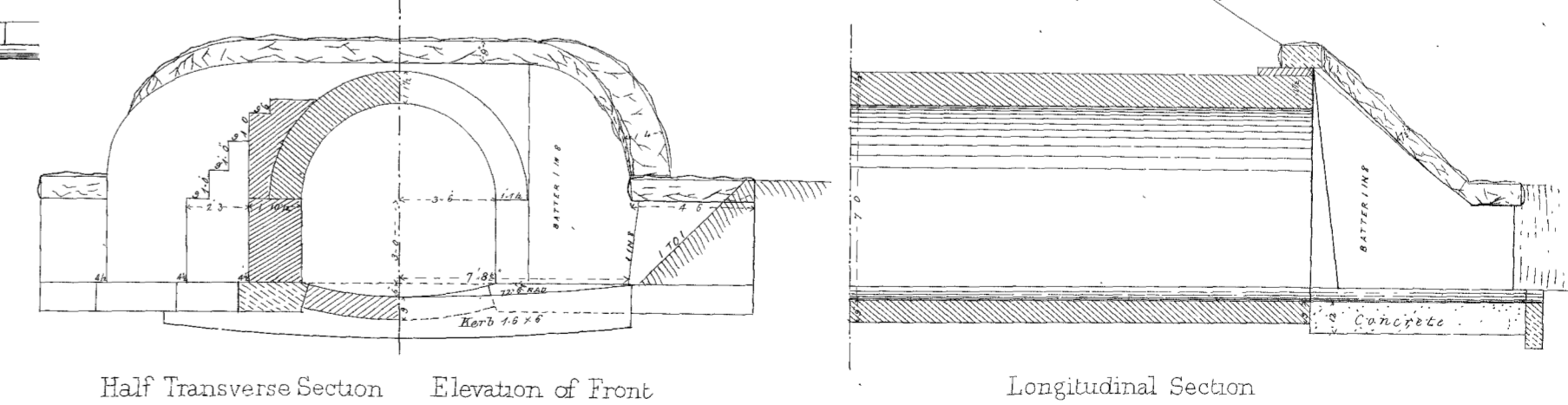

RAILWAY DEPARTMENT, MELBOURNE, NOV^r 1875

*This is one of the Drawings referred to in the Specification
when signed we dated the 24th day of December 1875
Witness to Signatures, Fisham, Morton & Adam
J. S. Adams
6/1/74*

PRINTED AND SOLD BY
MAR 7 - 1910